

Assembly Instructions



QUANTUM

Bluestreakequipment MAGNETICS
APPLICATION DRIVEN DESIGN

Bluestreak Equipment
1645 Hwy #3, Delhi, Ontario, Canada N4B 2W6

What's in the Box - Parts

A) Quantum Front Frame, Drum and Magnet Assembly - 1 pc

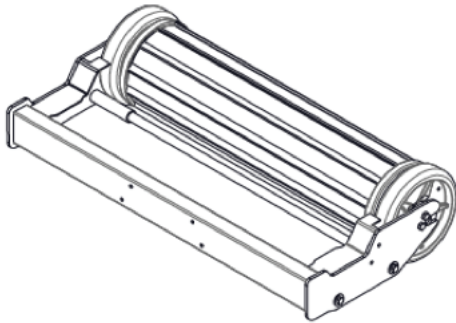

B) Quantum Lower Handles - 2 pcs



C) Quantum Upper Handles - 2 pcs



D) Quantum Right Caster Bracket - 1 pc

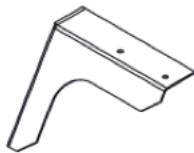

E) Quantum Left Caster Bracket - 1 pc

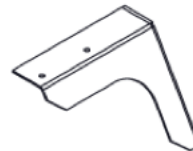

F) Quantum 6 Inch Caster Wheel - 1 pc



G) Quantum Debris Bin Body - 1 pc

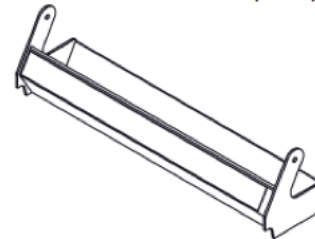

H) Quantum Debris Bin Handle - 1 pc



What's in the Box - Fasteners & Small Parts

i) 1/4" x 3/4" Hex Bolts - 4 pcs



J) 1/4" x 1 1/2" Hex Bolts - 4 pcs



K) 1/4" x 2 1/4" Hex Bolts - 4 pcs



L) 1/4" x 3 1/2" Hex Bolts - 2 pcs



M) 3/8" x 1" Hex Bolts - 2 pcs



N) 1/4" Washers - 28 pcs



O) 3/8" Washers - 2 pcs



P) 1/4" Nyloc Nuts - 14 pcs



What's in the Box - Tools Needed

7/16" Wrench - 2 pcs

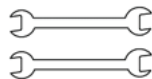

9/16" Wrench - 2 pcs



Step 1. Attach Lower Handles to End Plates

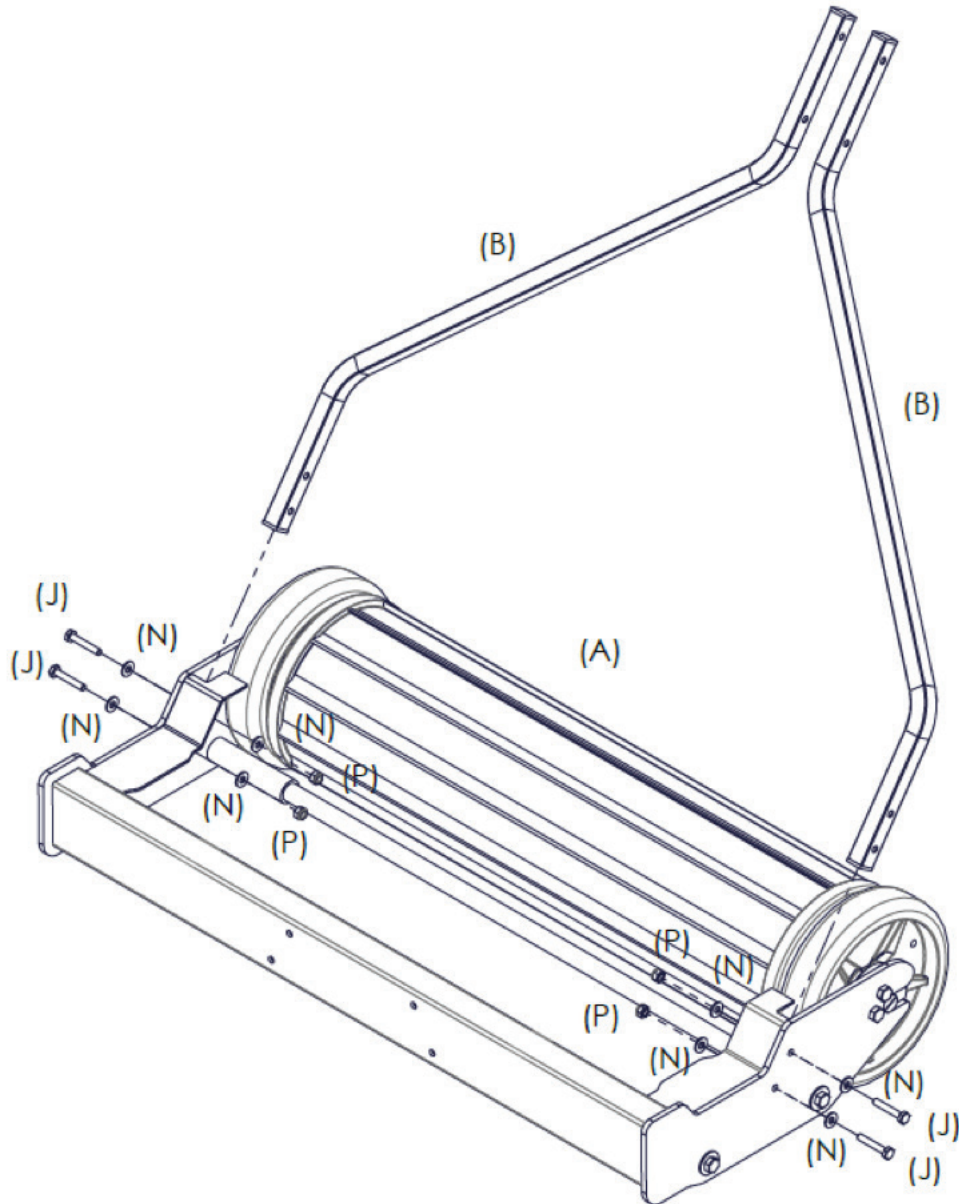

- (1) Attach Lower Handles to End Plates
 - a. Slide the lower handle (Item B) in through the slot on the bin alignment piece on the main assembly (Item A), with the end of least distance between the holes at the bottom.
 - b. Attach the lower handles (Item B) to the end plates in the main assembly (Item A) using 2 pcs 1/4" x 1 1/2" Hex Bolt (Item J), 4 pcs 1/4" Washer (Item N) and 2 pcs 1/4" Nyloc Nuts (Item P).
 - c. Repeat for opposite side to make both the left- and right-hand assembly.

Note: Do not tighten these bolts until after step 2.

Step 2. Attach Upper Handles to Lower Handles

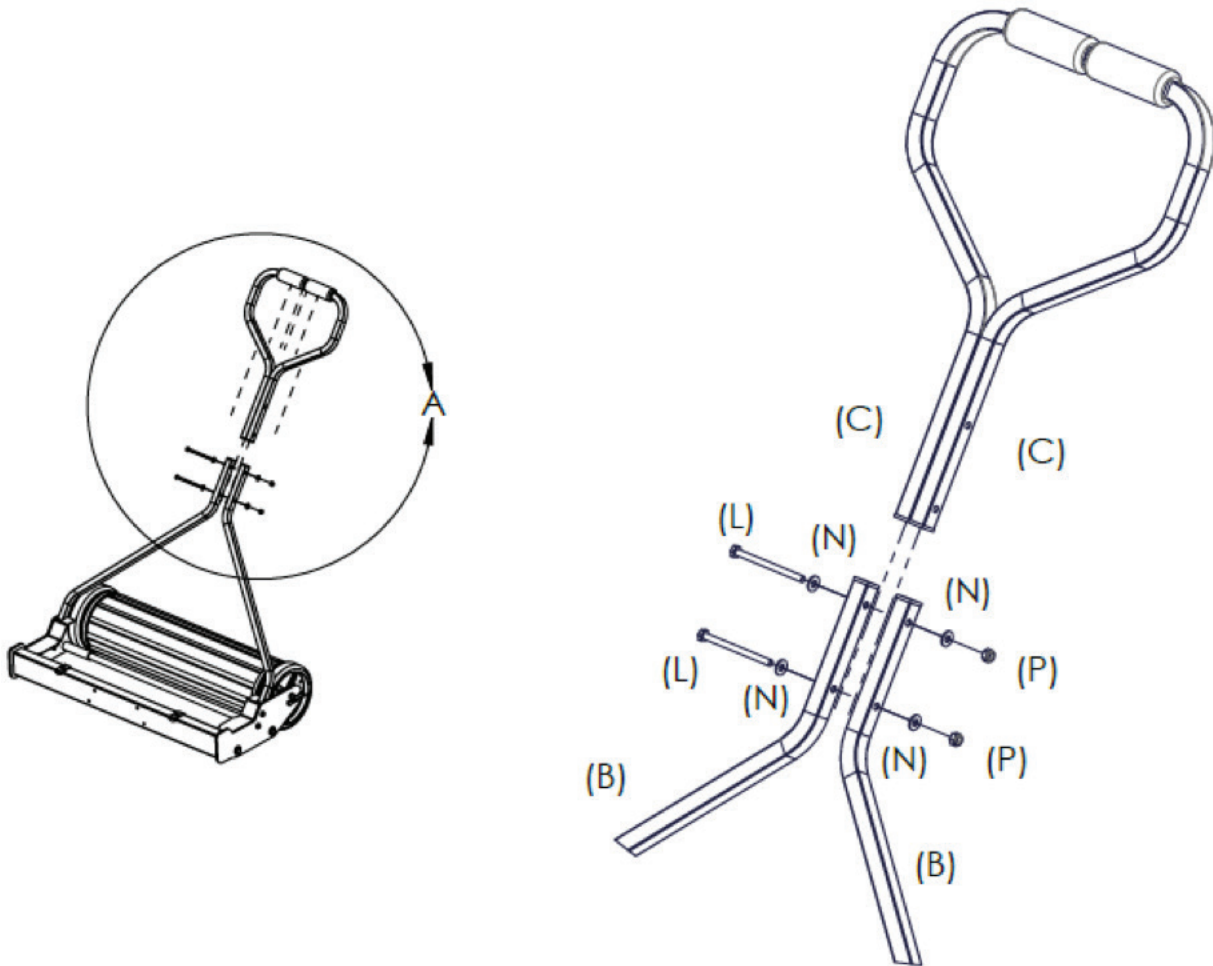

DETAIL A
SCALE 1 : 8

- (1) Attach Upper Handles to Lower Handles
 - a. Attach upper handles (Item C) to lower handles (Item B), with the hand grips facing each other, using 2 pcs 1/4" x 3 1/2" Hex Bolt (Item L), 4 pcs 1/4" Washers (Item N), and 2 pcs 1/4" Nyloc Nuts (Item P).

Note: Tighten the bolts on both upper and lower handles.

Step 3. Attach Caster Wheel to Caster Brackets

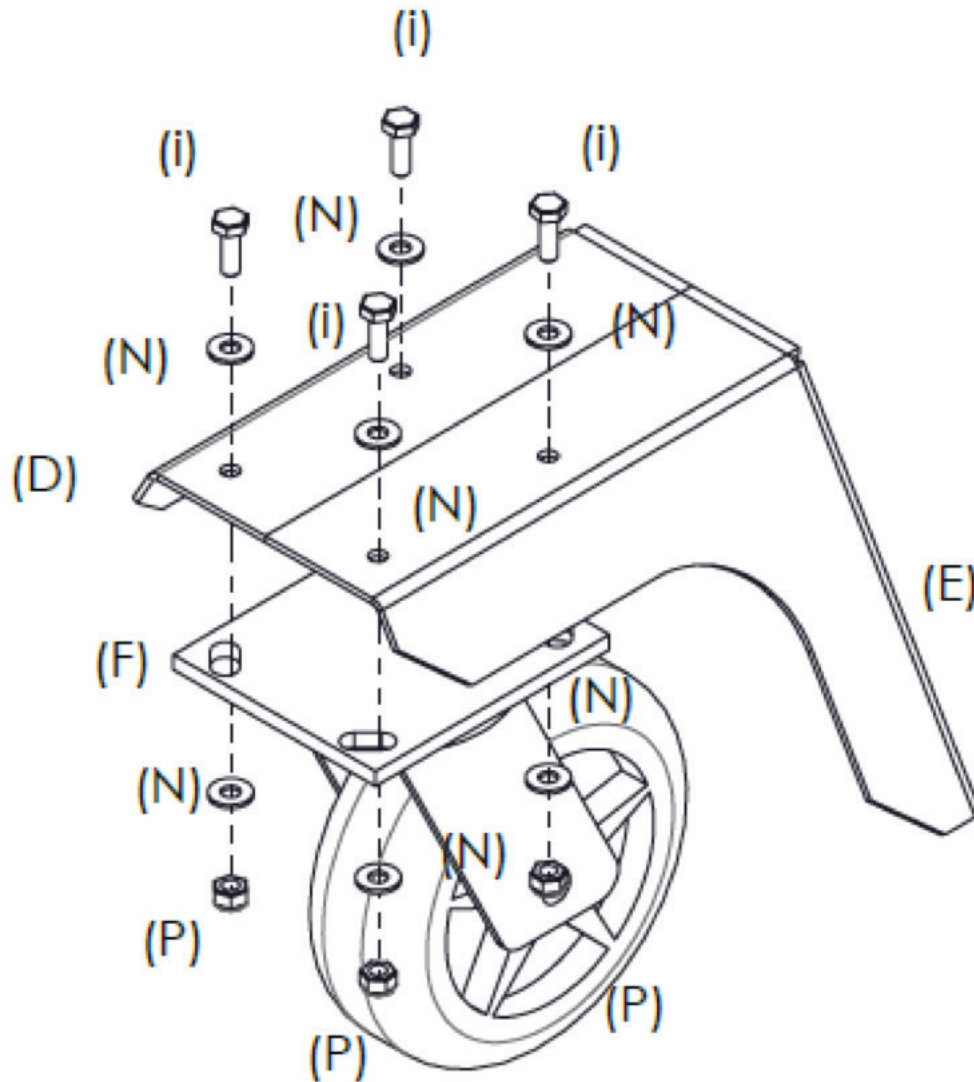

- (1) Attach 6 Inch Caster Wheel onto Caster Brackets
 - a. Attach the 6 inch caster wheel (Item F) to the caster brackets (Item D and E) from below using 4 pcs 1/4" x 3/4" Hex Bolt (Item i), 8 pcs 1/4" Washer (Item N) and 4 pcs 1/4" Nyloc Nuts (Item P).

Note: Align the two pcs of caster brackets and keep them in contact.

Note: Tighten the bolts between caster brackets and caster wheel.

Step 4. Attach Caster Brackets to Front Frame

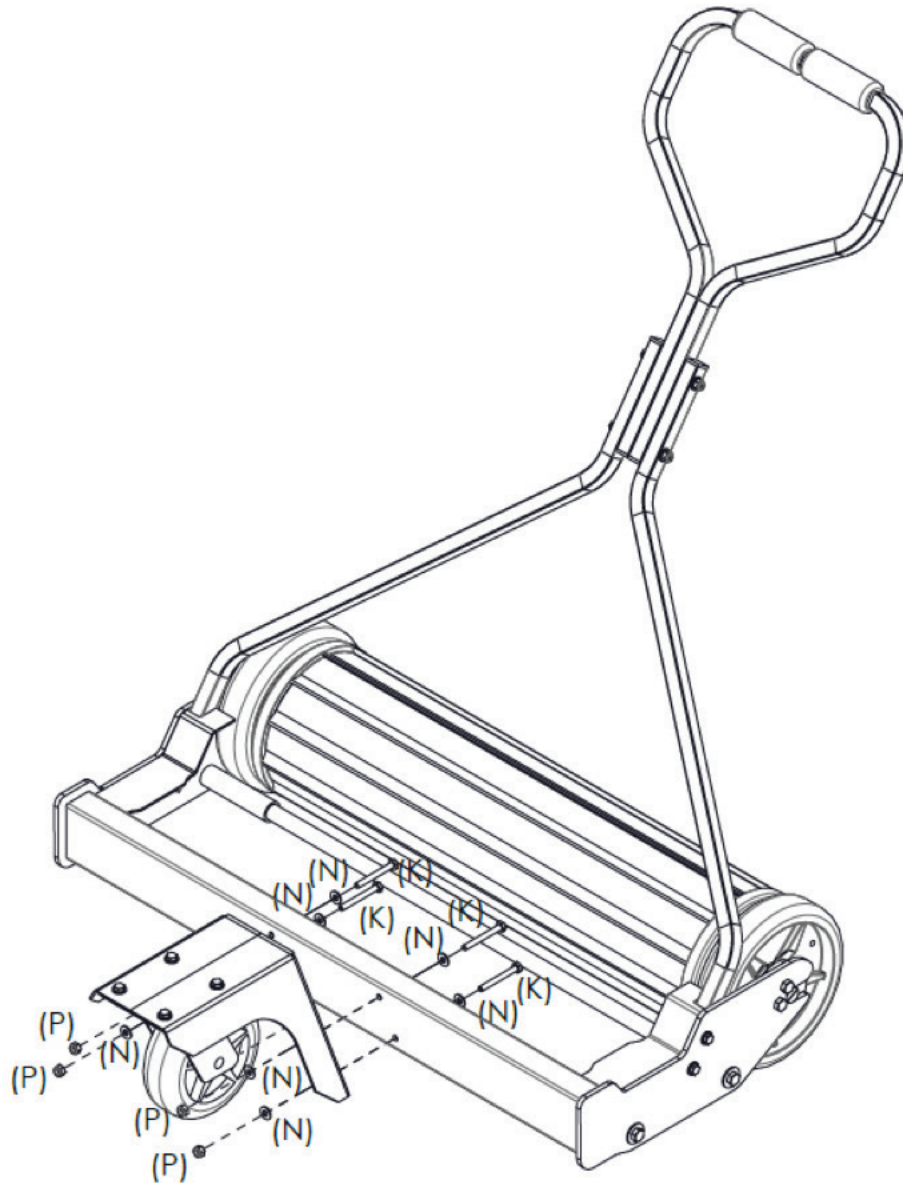

- (1) Attach Caster Brackets to Front Frame (on Main Assembly)
 - a. Attach the left (Item E) and right (Item D) caster bracket to the front frame on main assembly (Item A) using 4 pcs 1/4" x 2 1/4" Hex Bolt (Item K), 8 pcs 1/4" Washer (Item N) and 4 pcs 1/4" Nyloc Nuts (Item P).

Note: Tighten the bolts between caster brackets and front frame.

Step 5. Debris Bin Assembly

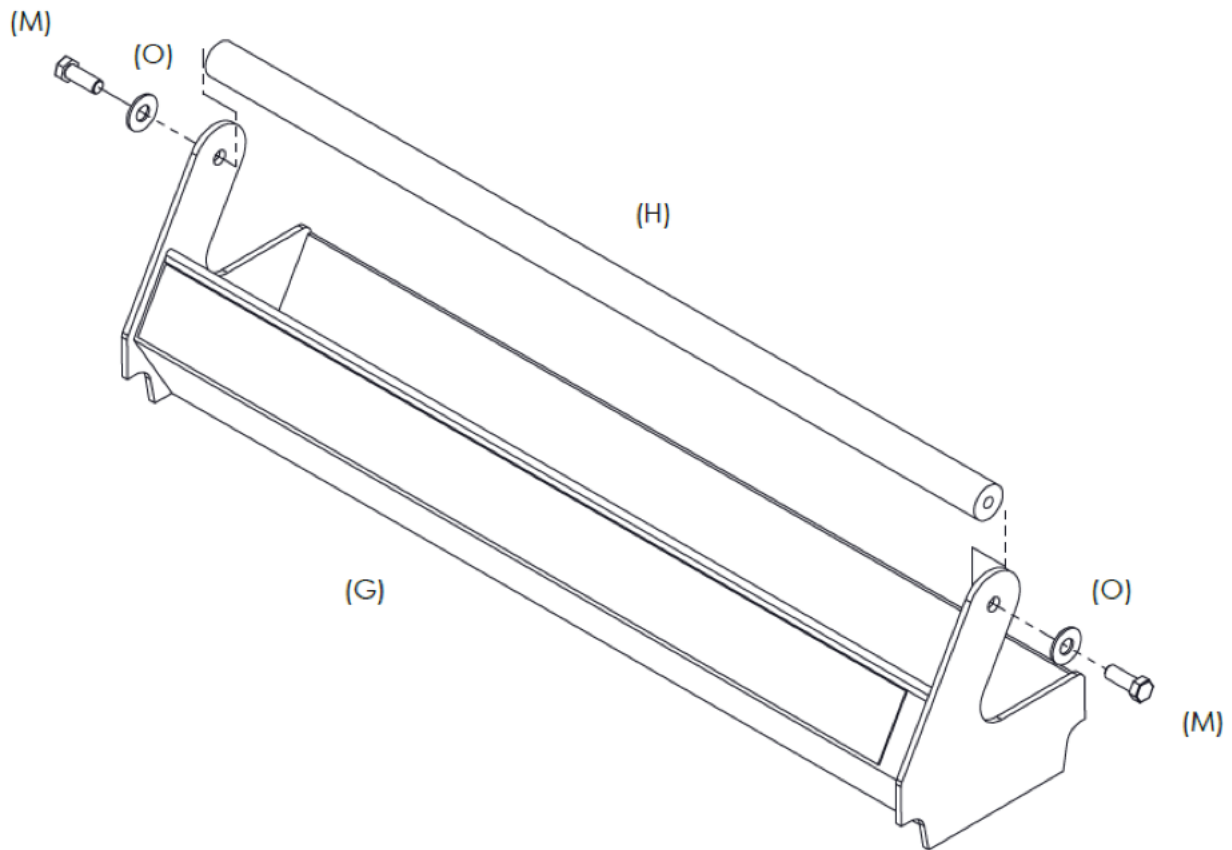

- (1) Debris Bin Assembly
 - a. Attach the debris bin handle (Item H) to the debris bin body (Item G) using 2 pcs 3/8" x 1" Hex Bolts (Item M), and 2 pcs 3/8" Washers (Item O).

Note: Tighten bolts firmly.

Step 6. Set Debris Bin Assembly in Place

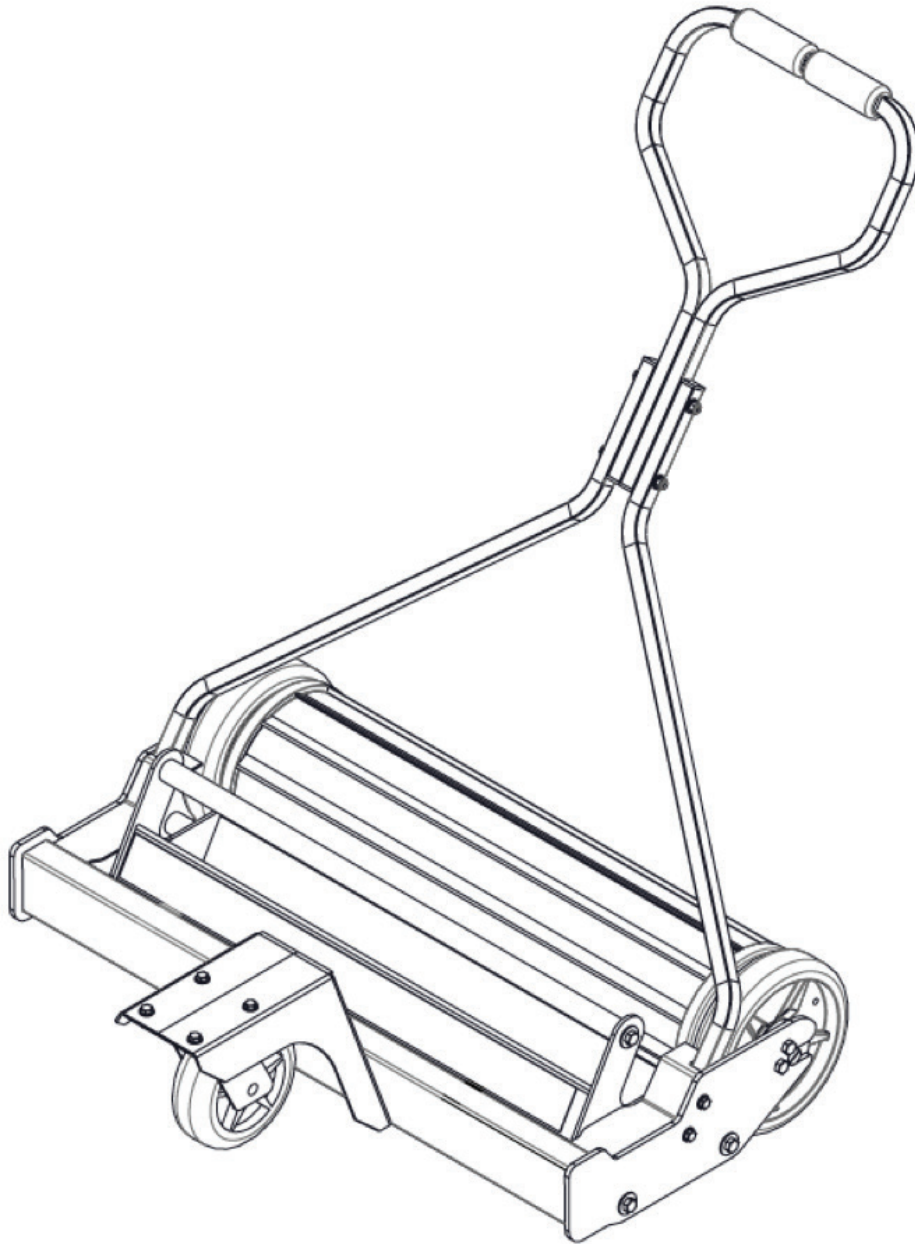

- (1) Set Debris Bin Assembly in Place
 - a. Set the debris bin assembly in front of the magnetic sweeper on top of the bin support rods.

Bluestreak Equipment • 1645 Hwy #3, Delhi, Ontario, Canada N4B 2W6

www.blustreakequipment.com